

## FITTING INSTRUCTION

Clamp mark in acc. with		Cables joining
ISO	PN	
1	L	Left directional lights
2	+	Rear fog lights
3	31	Ground
4	R	Right directional lights
5	58R	Right side parking lights
6	54	Stoplights
7	58L	Left side parking lights

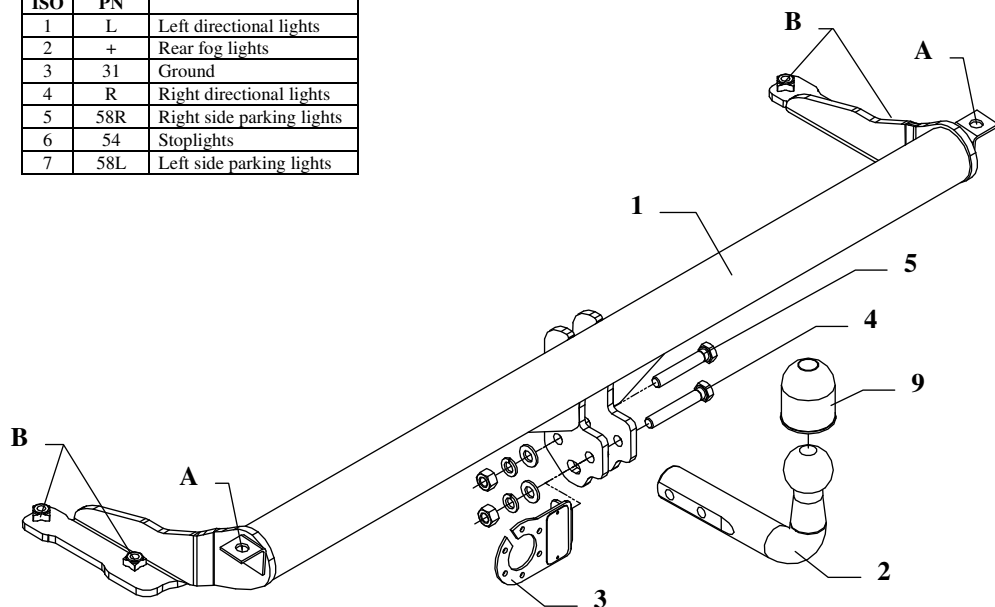

This towing hitch is designed to assembly in following cars: **VOLKSWAGEN GOLF II, 3/5 door, narrow bumper**, produced since 08.1983 till 10.1991 and **VOLKSWAGEN JETTA II, narrow bumper**, catalogue no. **K04** and is prepared to tow trailers max total weight **1300 kg** and max vertical mass **75 kg**.

### *From manufacturer*

Thank you for buying our product. Their reliability has been confirmed in many tests. Reliability of towing hitch depends also on correct assembly and right operation. For this reasons we kindly ask to read carefully this instruction and apply to hints.

*The towing hitch should be install in points described by a car producer.*

## The instruction of the assembly

1. Disassemble the bumper – unscrew four bolts M10 from the left and right side (from the bottom of the car).
2. Unscrew original brackets from the bumper.
3. In places disassembled brackets fix bumper to the main bar of the towing hitch (pos. 1) through holes (pos. A).
4. Put that prepared bumper with towing hitch and fix it to the car using bolts M10 (original from disassembled bumper - 4 pcs.) through holes (pos. B).
5. Fix tow ball (pos. 2) using bolt M12x75mm (pos. 4) and M12x70mm (pos. 5). With bolt M12x75mm fix also a socket plate (pos. 3). See figure 1.
6. Tighten all bolts according to the torque shown in the table.
7. Connect electric wires of 7-poles socket according to the instruction of the car. (Recommend to make at authorized service station).
8. Complete paint layer damaged during installation.

Torque settings for nuts and bolts (8,8):	
<b>M 8</b> - 25 Nm	<b>M 10</b> - 55 Nm
<b>M 12</b> - 85 Nm	<b>M 14</b> - 135 Nm







### NOTE

After install the towing hitch you should get adequate note in registration book (at authorised service station).The car should be equipped with:

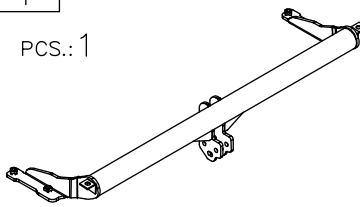
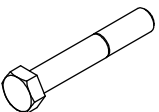
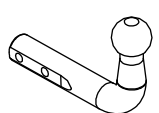
- Indicators
- Tow mirrors

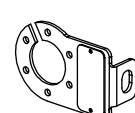
After 1000km of exploitation check all bolts and nuts. The ball of towing hitch must be always kept clear and conserve with a grease.

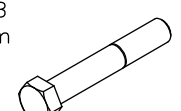
## Towing hitch accessories:

Pos. 1	Main bar 	Pos. 5	Bolt 8,8 B M12x70mm 
PCS.: 1		PCS.: 1	
Pos. 2	Tow ball 	Pos. 6	Nut 8 B M12 
PCS.: 1		PCS.: 2	
Pos. 3	Socket plate 	Pos. 7	Plain washer Ø12mm 
PCS.: 1		PCS.: 2	
Pos. 4	Bolt 8,8 B M12x75mm 	Pos. 8	Spring washer Ø12mm 
PCS.: 1		PCS.: 2	
		Pos. 9	Ball cover 
		PCS.: 1	



## PPUH AUTO-HAK S.J.

Produkcja Zaczepów Kulowych  
Henryk & Zbigniew Nejman  
76-200 SŁUPSK ul. Słoneczna 16K  
tel/fax (059) 8-414-414; 8-414-413  
E-mail: [office@autohak.com.pl](mailto:office@autohak.com.pl)  
[www.autohak.com.pl](http://www.autohak.com.pl)

### Towing hitch (without electrical set)

Class: **A50-X** Cat. no. **K04**

Designed for:

Manufacturer: **VOLKSWAGEN**

Model: **GOLF II**

Type: **3/5 door, narrow bumper**

produced since 08.1983 till 10.1991

Model: **JETTA II**

Type: **narrow bumper**

Approval number acc. to regulations EKG/ONZ 55.01: **E20-55R-01 0945**

Technical data:

**D-value: 6,95 kN**

maximum trailer weight: **1300 kg**

maximum vertical cup mass: **75 kg**

### Foreword

This towing hitch is designed according to rules of safety traffic regulations. The towing hitch is a safety component and can be install only by qualified personnel. Any alteration or conversion of the towing hitch is prohibited and would lead to cancellation of design certification. Remove insulating compound and underseal from vehicle (if present) in the area of the matting surfaces of the towing hitch.

The vehicle manufacturer's specifications regarding trailer load and max. vertical cup load are decisive for driving whereat values for the towing hitch cannot be exceeded.

*D-value formula:*

$$\frac{\text{Max trailer weight [kg]} \times \text{Max vehicle weight [kg]}}{\text{Max trailer weight [kg]} + \text{Max vehicle weight [kg]}} \times \frac{9,81}{1000} = D \text{ [kN]}$$